

The **DAFNE** couch is a 2-section, fixed height couch. The couch is suitable for examination and traction therapy and is used by rehabilitation and physiotherapy professionals. The couch is equipped for lumbar and cervical traction and with a removable traction unit mounting and with retractable castors.

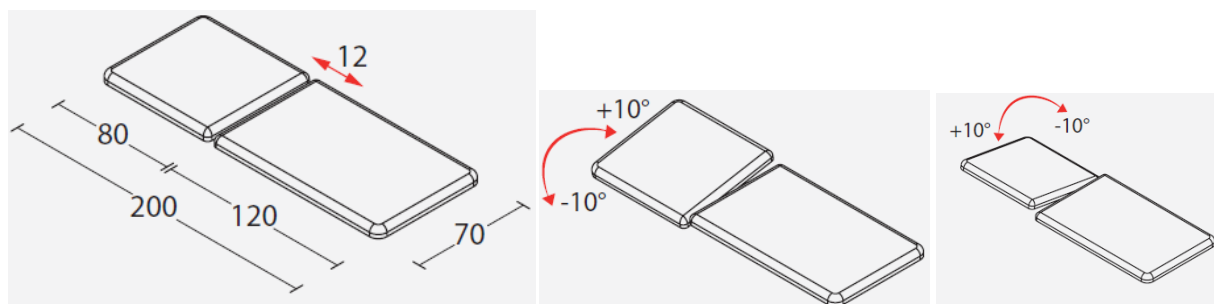

TECHNICAL SPECIFICATIONS

Sections	2
Backrest tilt	10°
Main section sliding by	12 cm
Under bed clearance	28 cm
Width	70 cm
Length	200 cm
Max working load, evenly distributed	200 kg
Fixed height	65 cm
Adjustable feet	4
Weight	70 kg



FISIOTECH SRL

Operating Headquarters: Via Toniolo, 44/E-F - 31028 Vazzola (TV) - ITALY

Registered Office: Via Valdoni, 19 - 31013 Cimavilla di Codognè (TV) - ITALY

Tel. +39 0438470342 - Fax +39 0438478762 - mail : info@fisiotech.com - pec :

fisiotech@emailsec.it

VAT Number IT 03765100262 - Rea TV 296956

DAFNE COUCH MODELS

Descrizione	Codice
Dafne	1114B12S0N

TECHNICAL SPECIFICATIONS – PADDING

Name of material	Polyurethane foam
Reaction to fire class	1 IM (highest)
Density	30 kg/m ³
Height	40 mm



AVAILABLE UPHOLSTERY COLOURS

 Beige P1	 Light grey G2	 Taupe P2	 Dark grey G3	 Yellow G1
 Mustard G4	 Orange A1	 Red R1	 Burgundy B2	 Violet V4
 Dark blue B3	 Blue B1	 Dark brown M1	 Earth M2	 Green V1
 Forest green V2	 Leaf green V3	 Black N1		

FISIOTECH SRL

Operating Headquarters: Via Toniolo, 44/E-F - 31028 Vazzola (TV) - ITALY

Registered Office: Via Valdoni, 19 - 31013 Cimavilla di Codognè (TV) - ITALY

Tel. +39 0438470342 - Fax +39 0438478762 - mail : info@fisiotech.com - pec :

fisiotech@emailsec.it

VAT Number IT 03765100262 - Rea TV 296956

TECHNICAL SPECIFICATIONS – UPHOLSTERY

FEATURE	TEST METHOD	UNIT	LIMIT VALUE
Tensile strength	UNI EN ISO 1421 Method 1	N	Lengthwise ≥ 210 Crosswise ≥ 90
Elongation strength	UNI EN ISO 1421 Method 1	%	Lengthwise ≥ 85 Crosswise ≥ 140
Determination of tear force	EN ISO 13937-2: 2000	daN	Lengthwise $\geq 2,5$ Crosswise $\geq 2,2$
Colour fastness to crocking	UNI EN ISO 105 X12: 2003 UNI EN ISO 105 D02: 1998	grey scale	Dry 4 Bleach 4/5 Ethyl alcohol 3/4
Determination of abrasion resistance: Martindale abrader	UNI EN ISO 5470-2: 2004	cycles	Method 1 (direct) 65.000 Method 2 (reverse) 210.000
Reaction ignition Fireproof class	UNI 9175: 1987 UNI 9175/FA1: 1994		CLASSE 1.IM
Free and hydrolyzed formaldehyde	UNI EN ISO 14184-1: 2011	mg/Kg	< 3
Phtalates	UNI EN ISO 14389: 2014	%	< 0,06
Arylamines	UNI EN ISO 14362-1: 2012	mg/Kg	Not detectable
Cleaning	Clean with damp soapy cloth and rinse well with clean water. Do not use solvents, bleaches, synthetic detergents, polishes or aerosol spray.		
Specific features	Antibacterial Fingicide		
Composition	Plasticised PVC 88% - Polyester 12%		

FIRE RESISTANCE ACCORDING TO:
IMO - 2010 FTP CODE Part 8
"Test for upholstered furniture"
par 7.2 SMOULDERING CIGARETTE TEST
par 7.3 PROPANE FLAME TEST
EN 1021-1: 2006 smouldering cigarette test
EN 1021-2: 2006 match flame equivalent test

FISIOTECH SRL

Operating Headquarters: Via Toniolo, 44/E-F - 31028 Vazzola (TV) - ITALY





Registered Office: Via Valdoni, 19 - 31013 Cimavilla di Codognè (TV) - ITALY

Tel. +39 0438470342 - Fax +39 0438478762 - mail : info@fisiotech.com - pec :

fisiotech@emailsec.it

VAT Number IT 03765100262 - Rea TV 296956

DAFNE COUCH FULL EQUIPMENT

<p>4 adjustable feet</p>	
<p>Spreader bar for pelvic harness.</p>	
<p>Thoracic harness. Available in two sizes (small and large)</p>	
<p>Pelvic harness. Available in two sizes (small and large)</p>	
<p>Head halter and spread bar.</p>	
<p>Trapezoid cushion. Dimensions: 40X50X30 cm. The cushion colour corresponds with the couch colour.</p>	
<p>Wedge cushion. Dimensions: 45x45x15 cm. The cushion colour corresponds with the couch colour.</p>	
<p>Half-roll cushion. Dimensions: 30x16x8 cm. The cushion colour corresponds with the couch colour.</p>	

FISIOTECH SRL

Operating Headquarters: Via Toniolo, 44/E-F - 31028 Vazzola (TV) - ITALY

Registered Office: Via Valdoni, 19 - 31013 Cimavilla di Codognè (TV) - ITALY

Tel. +39 0438470342 - Fax +39 0438478762 - mail : info@fisiotech.com - pec :

fisiotech@emailsec.it

VAT Number IT 03765100262 - Rea TV 296956